

Hurricane Series - ECH40

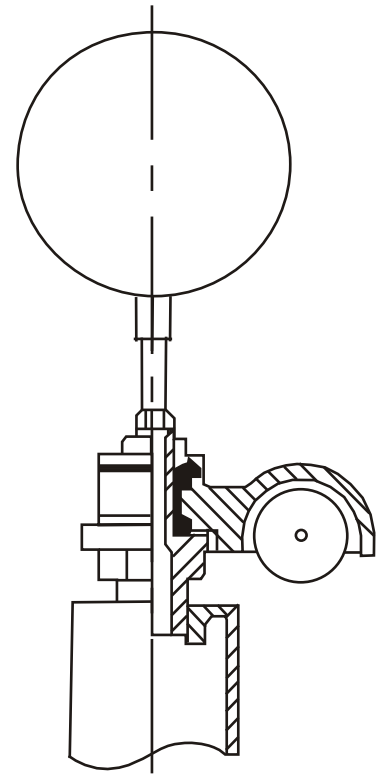
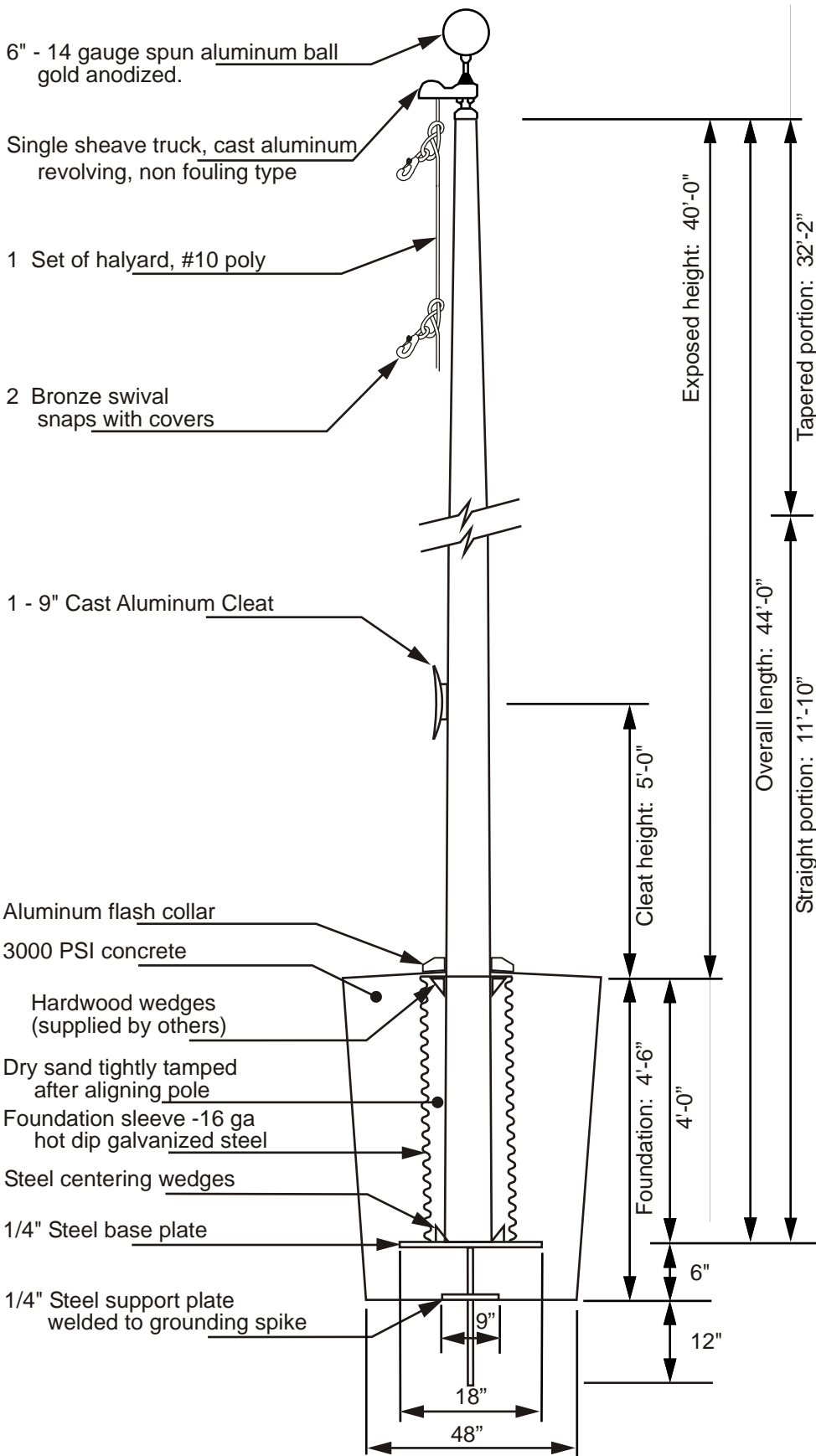

Truck Detail

- Aluminum body
- Stainless steel ball bearings
- Aluminum sheave
- Cast aluminum spindle

All shafts with overall length of more than 38'-6" are shipped in two sections.

Each section matched marked for field assembly. Exposed portion of jam sleeve must be **well lubricated** prior to assembly.

1-1/2" maximum shop gap allowed for field fitting (ram for tight joint)

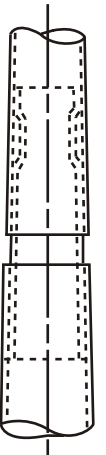

Project:	Ground set tapered aluminum flagpole: ALLOY: 6063T6	Flagpolewarehouse	Date:
Location:	Exposed height: 40'-0" Overall height: 44'-0"	3600 Cantrell Industrial Court	Revision:
Architect:	Ship in 2 sections Butt diameter: 8"	Acworth, GA 30101	
Contractor:	Top diameter: 3-1/2" Wall thickness: .250"		
Customer:	Finish:		Job: