

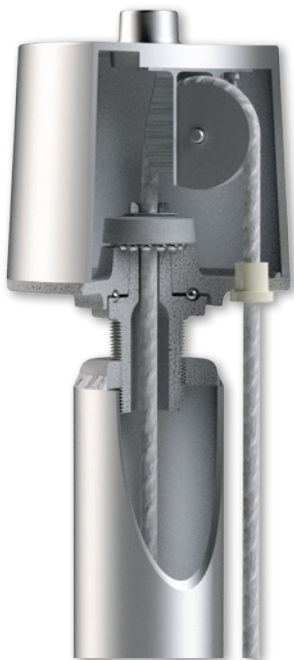

Internal Halyard Revolving Truck



Internal Halyard Revolving Truck Cutaway



Internal Halyard Stationary Truck



INSTALLATION INSTRUCTIONS IH-CAM-100

INTERNAL HALYARD FLAGPOLE SYSTEM

GROUND SET and SHOE BASE

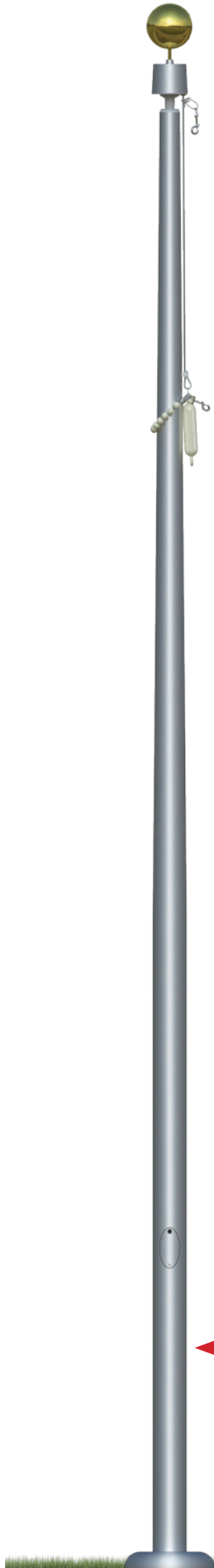

WARNING:

To prevent staining the flagpole must be stored in a dry place OR all packaging must be removed immediately after receiving shipment.



FOR QUICK AND PROFESSIONAL INSTALLATIONS READ ALL INSTRUCTIONS BEFORE PROCEEDING

Lay out all flagpole components. If a part is missing from the attached parts diagram, please contact your American Flagpole Dealer for replacement.

STEP 1 - Remove all wrapping materials and place unwrapped flagpole on cribbing or other wood support on ground (preferably in a covered dry area). If flagpole is **MULTI-SECTION**, carefully lay sections out in proper order, grouping flagpole sections with like match marks. Sections **MUST BE STRAIGHT & LEVEL** while sliding together. Line up match mark numbers, imprinted at each section, for proper fit. Lightly sand away any burrs that may be present on the male section or in the upper section of the joint. A small amount of lubrication (*silicone or dish washing liquid – by others*) may be applied to the male portion of the joint for easier fitting. Start with the bottom sections and work toward the top. Begin sliding the two sections, rolling the flagpole by 180° with every 2 to 3 inches to facilitate an easier fit. If extreme difficulty is found in fitting the first 6 inches together, pull back apart and cool the male section with ice for several minutes. A sledgehammer and block of wood (to protect the flagpole from direct impact) may be necessary on larger poles to complete the assembly of joints. American Flagpole suggests the use of an epoxy adhesive for flagpoles 60' and greater.

STEP 2 - Identify parts and place them along the flagpole according to the parts diagram.

STEP 3A (REVOLVING TRUCK) - Slide beaded retainer sling assembly (*PART E*) and assemble to end of cam cleat rope assembly with provided shackle. Take the rope halyard (*PART C*), temporarily remove the Halyard Securing Device (*PART J*). Open truck (*PART B*) by removing screws. Feed end of cam cleat rope halyard assembly up through nylon fitting in truck housing, up over the pulley inside the truck's hood, and back down through the threaded spindle of the truck assembly. Pull a few feet of the rope halyard through truck and re-assemble truck. **VERIFY HOOD IS REPLACED SUCH THAT INSIDE PULLEY IS DIRECTLY OVER CABLE ENTRANCE.** Feed the rope halyard down through the flagpole until you can pull it out through the cam cleat door near the base of the flagpole (*this may require a fish tape*).

STEP 3B (STATIONARY TRUCK) - Slide beaded retainer sling assembly (*PART E*) and assemble to end of cam cleat rope assembly with provided shackle. Take the rope halyard (*PART C*),

temporarily remove the Halyard Securing Device (*PART J*), and feed the halyard through the outer pulley of the stationary truck (*PART B*) and over the centering pulley. Feed the rope halyard down through the flagpole until you can pull it out through the cam cleat door near the base of the flagpole (*this may require a fish tape*).

STEP 4 – Next install the finial ball (*PART A*) by screwing the ball's spindle into truck (*PART B*). **Do not grip ball to tighten, grip spindle/rod with vise grips and tighten.** Tighten all nuts and set screws. An epoxy or Loc-tite type product is recommended on all connections (*supplied by others*).

STEP 5 – With the rope halyard installed in the truck and fed down the center of the flagpole, next feed rope halyard through the cam action cleat (*PART F*) which should be mounted to plate located inside door. Once through this device, pull excess through door, coil, and secure to outside of flagpole with tape.

STEP 6A (REVOLVING TRUCK) - Attach the truck (*PART B*) with ball by screwing into the threaded top of the flagpole **Do not epoxy spindle of truck.** If truck (*PART B*) is a stationary truck, be sure to secure all set screws.

STEP 6B (STATIONARY TRUCK) - Mount the truck assembly (*PART B*). You will find set screws around the outer wall of this device. Once located, slide truck and ball assembly over the top of the flagpole and fasten the set screws tightly against the flagpole. This should set the truck and keep it from moving. Be careful not to catch the rope between the truck and the pole top.

STEP 7 - On the outside of the flagpole, space and/or adjust the snap hooks and neoprene covers (*PART D*) to the proper distance to accommodate your flag size. Please see diagram for snap hook attachment. Attach Counterweight and Beaded Retainer Sling Assembly (*PART E*) with provided shackle.

STEP 8 - Before standing flagpole, slide the flash collar (*PART G*) up from bottom and secure at the location of the cleat holes with tape on underside of flash collar to prevent slipping.

STEP 9 - Stand flagpole into previously installed ground sleeve (*Ground Set Installation*) or onto anchor bolts (*Shoe Base Installation*). This may require the use of a crane or backhoe for larger flagpoles. Always choke multiple section poles below lowest joint as a safety precaution. Caution: During installation, the flagpole should be assembled as close as possible to the final support point. Professionals experienced in such installations should perform rigging and lifting. During lift, keep clear of the area and reach of the flagpole path. Do not pass flagpole overhead. When installing multi-piece flagpoles, arrange the rigging for the lift in such a way that weight of the flagpole sections is supported from the bottom of the flagpoles so that the flagpole joints are pushed together, not pulled apart, during the lift. Keep clear of power lines.

STEP 10A (GROUND SET) - After inserting flagpole into ground sleeve (*corrugated tube*), plumb flagpole with wooden wedges (*supplied by others*). Fill space between ground sleeve and flagpole with tamped dry sand. Fill ground sleeve 6" to 8" at a time and tamp as you fill. Fill ground sleeve with sand to about 2" from top. Then cap off with waterproof cement. For PVC ground sleeve, insert flagpole into plastic sleeve, turn to align truck assembly with the wind, plumb flagpole, fill remaining void with dry sand, and top off with thin layer of waterproof cement or caulking.

STEP 10B (SHOE BASE) - After placing the flagpole on top of the anchor bolts, install flat washer, lock washer, and hex nut. **Tighten nut and verify that all threads are fully engaged.**
 NOTE: An installation using "double nuts" is not recommended by American Flagpole.

STEP 11A (GROUND SET) - After waterproof cement has dried slide flash collar (*PART F*) down into position and caulk joint with matching color silicone to seal the space between the flagpole and the flash collar.

STEP 11B (SHOE BASE) - After the nuts have been tightened, slide flash collar (*PART F*) down into position and caulk joint with matching color silicone to seal the space between the flagpole and the flash collar.

STEP 12 – HALYARD OPERATION: Pull rope halyard (*PART C*) to the right to clear cam operation. Carefully pull or release halyard to raise or lower the flag to the desired height. To secure the halyard, reach into the front on the cam, and lift the cam up. Pull halyard to the left, behind the cam. Release cam, halyard will engage the cleat and hold. Before flag is raised to the top of flagpole, raise Counterweight and Beaded Retainer Sling Assembly (*PART E*) to approximately two feet from top of cam cleat access door, and install the Halyard Securing Device (*PART J*) on the rope assembly, just below the cam cleat assembly, and tighten thumb screw to secure. Excess halyard should be pushed back through the cam cleat door for storage.

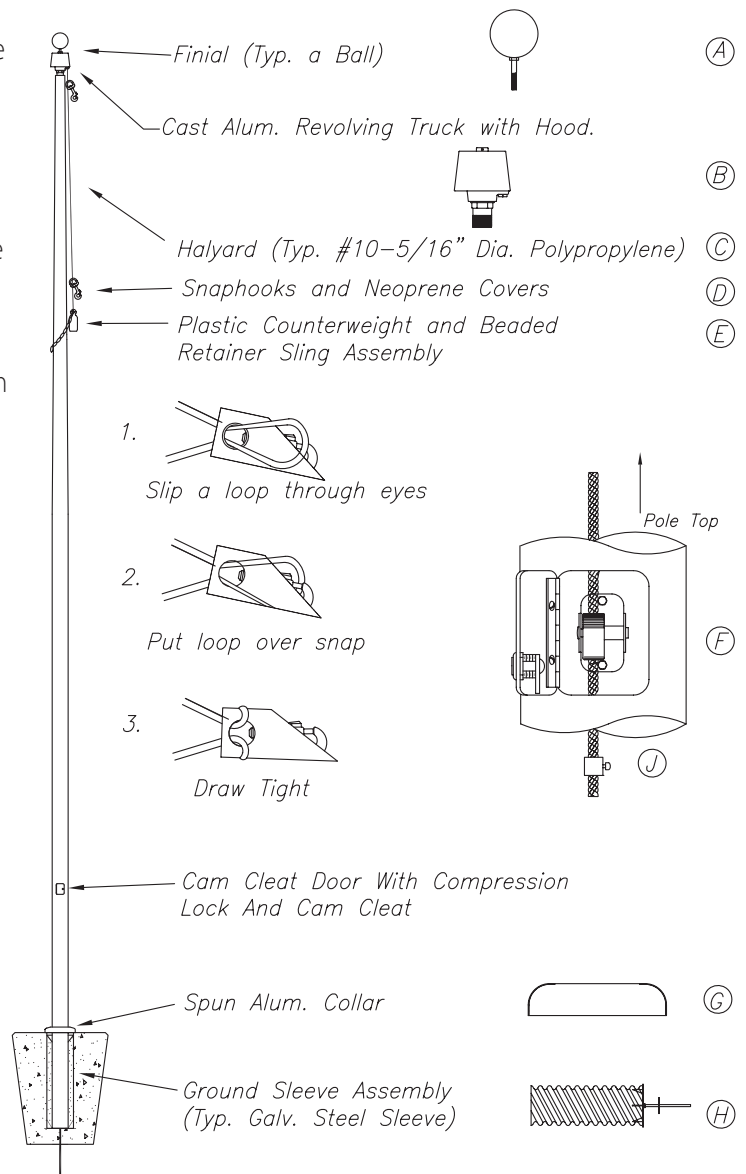

GROUND SLEEVE WITH STEEL LIGHTNING SPIKE INSTALLATION

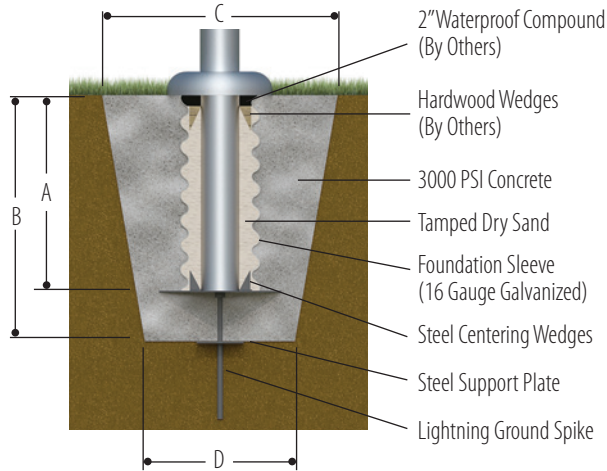

EXPOSED MOUNTING HEIGHT	A	B	C	D
20'-0"	2'-0"	2'-6"	30"	24"
25'-0"	2'-6"	3'-0"	36"	24"
30'-0"	3'-0"	3'-6"	36"	24"
35'-0"	3'-6"	4'-0"	36"	30"
40'-0"	4'-0"	4'-6"	45"	36"
45'-0"	4'-6"	5'-0"	45"	36"
50'-0"	5'-0"	5'-6"	50"	42"
60'-0"	6'-0"	6'-6"	60"	48"
70'-0"	7'-0"	7'-6"	60"	48"
80'-0"	8'-0"	8'-6"	72"	48"

NAAMM's Metal Flagpole Manual offers basic suggestions on foundation measurements in firm, dry soil only using dry tamped sand and 3000 PSI concrete. Soil conditions vary by site. Exact foundation requirements should be verified by a Structural Engineer with knowledge of soil conditions in your locality.

SHOE BASE FOUNDATION INSTALLATION

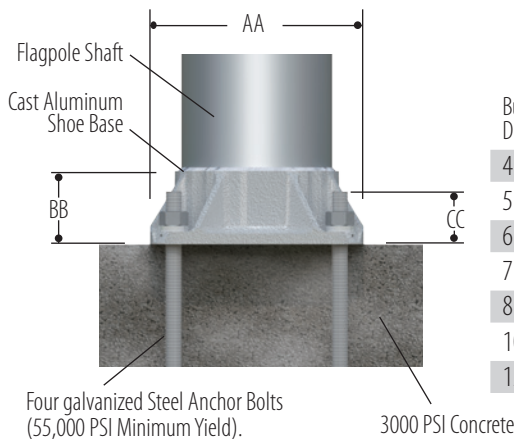

BUTT DIAMETER	AA BASE SQUARE	BB BASE HEIGHT	CC BOLT PROJECTION	BOLT DIAMETER	BOLT CIRCLE DIAMETER
4"	7-1/2"	3"	2"	3/4"	6-1/2" - 8"
5"	7-1/2"	3"	2"	3/4"	7 1/2" - 8"
6"	9-3/4"	3-1/2"	2-3/4"	1"	9" - 10"
7"	10-1/2"	3-11/16"	2-3/4"	1"	10" - 11"
8"	11-1/4"	3-15/16"	2-3/4"	1"	11" - 12"
10"	14"	4-7/8"	3-1/4"	1"	14" - 15"
12"	17"	8"	3-3/4"	1-1/4"	16" - 18"

